

## 2.5Gb/s CWDM Buried Het Laser non-WDM applications

### LC25WZ

#### Features:

- 2.5Gb/s operation
- Narrow spectral line-width
- Internal TEC with precision NTC thermistor for temperature control
- Code reduction with single product for reaches up tp 175km
- GaInAsp SLMQW DFM single frequency laser chip
- InGaAs monitor Photodiode
- Hermetically sealed 14-pin butterfly package with optical isolator
- RoHs compliant 

#### Applications:

- TDM
- On-off ramps
- Long-Haul



This laser module employs the Oclaro strained layer MQW Buried Heterostructure DFB laser chip, and has been designed specifically for use in 2.5Gb/s long distance single channel optical fiber systems. The device is packaged in a hermetically sealed 14-pin butterfly package incorporating an isolator and monitor photodiode for control of the power of the laser over life and all operating conditions.

## Parameters

Parameters	Conditions	Min	Typ	Max	Unit
Threshold current ( $I_{th}$ )			10	22	mA
Slope efficiency by product	2 mW 3 mW 4 mW 10 mW	0.04 0.06 0.08 0.143		0.09 0.13 0.17 0.43	mW/mA
RF input reflection coef ( $S_{11}$ )	(1)			-10	dB
Forward voltage			1.3	1.8	V
Channel wavelengths available	ITU G.694.2	1470		1610	nm
Peak wavelength for channel	(2)	$\lambda_p - 4\text{nm}$	$\lambda_p$	$\lambda_p + 4\text{nm}$	nm
Dispersion penalty at 80 km	(3)			2	dB
Time averaged spectral linewidth	-20 dB		0.1	0.6	nm
Side-mode suppression		30	40		dB
Optical rise/fall time	(4)			125	ps
Monitor photo current		50	250	1200	$\mu\text{A}$
Monitor dark current				100	nA
Thermistor resistance			10		k $\Omega$
Heatpump current	70°C case temperature	250	600	900	mA
Heatpump voltage	70°C case temperature		1.0	2.4	V
Change of $\lambda_p$ with laser temp.	20 to 35		0.09		nm/°C

[1] 50  $\Omega$  measurement system, f = dc - 3GHz

[2] Submount temperature between 20°C to 35°C start of life to achieve required  $\lambda$ .

[3] Standard product dispersion penalty will be compliant to the specified link length of 80km using an extinction ratio of 10dB. Fiber dispersion characteristics are derived from the following equation.

$$D(\lambda) = \frac{S_0}{4} \left( \lambda - \frac{\lambda_0^4}{\lambda^3} \right) \text{ps}/(\text{nm.km})$$

Where  $S_0 = 0.092\text{ps}/(\text{nm}^2.\text{km})$  and  $\lambda = 1302\text{nm}$ .

(4) Measurements determined from 20 - 80% pk - pk.

### Absolute Maximum Ratings

Parameter	Min	Max	Unit
Case operating temperature	0	70	°C
Laser submount operating temperature	20	35	°C
Storage temperature	-40	85	°C
Laser current above I <sub>th</sub>		100	mA
Laser reverse voltage		1.0	V
Laser reverse current		10	µA
Monitor diode bias		-10	V
Heatpump voltage		2.4	V
Fiber bend radius	30		mm

### Outline Drawing

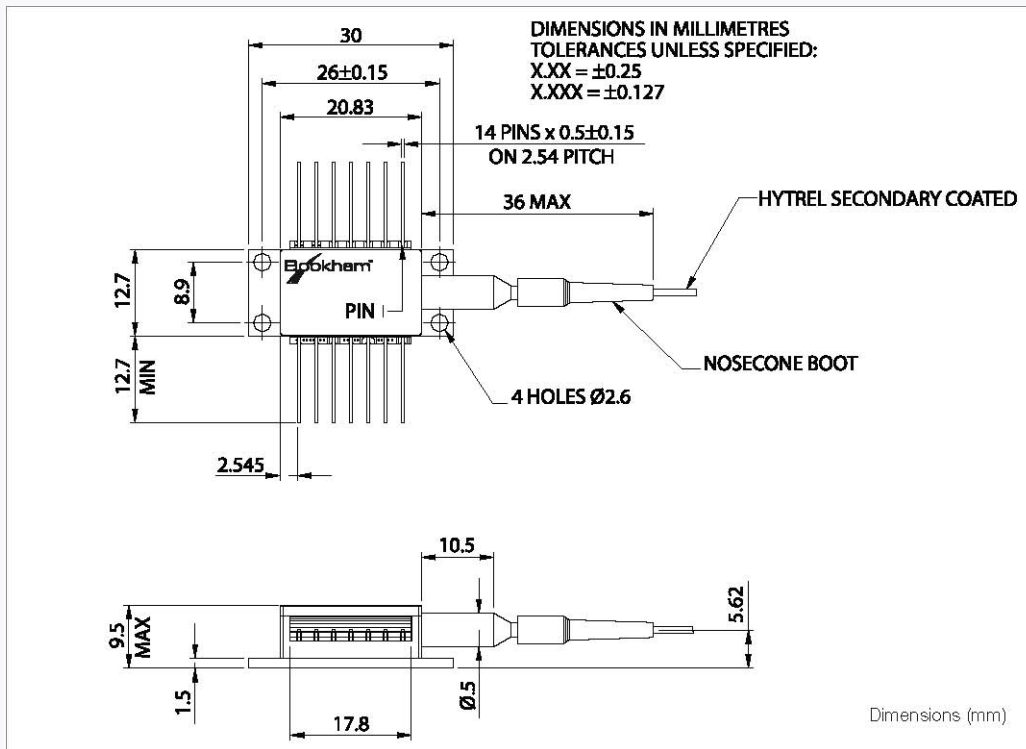

Figure 1: Outline Drawing

## Reliability/Quality

Meets Qualification requirements of Telcordia GR-468-CORE for Central Office environment.

Operating reliability <math><500 \text{ FITs}^1</math> in 15 years.

1- Assumes laser die submount held at <math><35^{\circ}\text{C}</math> by internal thermoelectric cooler, mean forward current of 35mA, and end of life limits based on 10mA increase in  $I_{th}$  and 25% change in laser efficiency. FIT rate data for other end of life criteria, including minimum extinction ratio requirements, are available upon request.

## Instructions for use – LC25WZ

### Pin 1 and Pin 2 Thermistor

The thermistor is used in a control loop in conjunction with the thermo-electric cooler to maintain the laser submount temperature at the required value for wavelength. Operating current should be less than 100 $\mu\text{A}$  to prevent self-heating errors.

### Pin 3 Laser DC bias (-)

Laser bias current (negative with respect to package ground) is applied via this pin which forms one side of the bias-T connection to the laser cathode.

### Pin 4 Monitor anodes, Pin 5 Common Monitor cathode

The back facet monitor provides a mean power reference for the laser and is normally operated with a 5V reverse bias.

### Pin 6 TEC (+), Pin 7 TEC (-)

Applying a positive voltage on pin 6 with respect to pin 7 will cause the internal submount to be cooled relative to the case temperature. Reversing the polarity will raise the submount temperature relative to the case. The TEC supply should be capable of delivering up to 0.9A at 2.4V.

### Pin 8, 9, 11, 13 Case ground

These pins must be grounded in all applications

### Pin 10

This pin is not connected and should be grounded if possible

### Pin 12 Laser modulation (-)

The data input (modulation current) is applied via this pin which is a nominal 25 $\Omega$  impedance coplanar line. For 10mW applications the end of life modulation current is 90mA maximum. For all other applications 60mA maximum modulation current should be provisioned.

### Pin 14 N/C

This pin is not connected. It should be grounded if possible.

## Connections

Pin #	Function	Pin #	Function
1	Thermistor	8	Case Ground
2	Thermistor	9	Case Ground
3	Laser DC bias (-)	10	Not Connected
4	Monitor Anode (-)	11	Case Ground
5	Monitor Cathode (+)	12	Laser Modulation (-)
6	TEC (+)	13	Case Ground
7	TEC (-)	14	Not Connected



**RoHS Compliance**

Oclaro is fully committed to environment protection and sustainable development and has set in place a comprehensive program for removing polluting and hazardous substances from all of its products. The relevant evidence of RoHS compliance is held as part of our controlled documentation for each of our compliant products. RoHS compliance parts are available to order, please refer to the ordering information section for further details.

**Ordering Information:**

For Low Power, 175km versions

LC25WZ	[Power Option]	A	[Connector]
	E=2mW pk	-	J28= SC/PC
	C=3mW pk	-	J34= FC/PC
	A=4mW pk	-	J57= LC
			J59= MU

For 10mW version

LC25WZB	[Reach Option]		[Connector]
	J=100km	-	J28= SC/PC
	A=175km	-	J34= FC/PC
		-	J57= LC
		-	J59= MU

Fiber length 1130 to 1190mm

E.g. LC25WZCA-J28 is a 3mW device with 175km reach and an SC connector.

LC25WZBJ-J34 is a 10mW device with 100km reach and an SC/PC connector

**Contact Information**

**North America**

**Oclaro Worldwide Headquarters**

2584 Junction Avenue  
 San Jose  
 CA 95134  
 USA

Tel: +1 408 919 1500

Fax: +1 408 919 6083

[www.oclaro.com](http://www.oclaro.com)

[sales@oclaro.com](mailto:sales@oclaro.com)

### Important Notice

Performance figures, data and any illustrative material provided in this data sheet are typical and must be specifically confirmed in writing by Oclaro before they become applicable to any particular order or contract. In accordance with the Oclaro policy of continuous improvement specifications may change without notice. The publication of information in this data sheet does not imply freedom from patent or other protective rights of Oclaro or others. Further details are available from any Oclaro sales representative.



BH13091 1.0 July 2009  
 ©Oclaro 2009. Oclaro the Oclaro, Inc. logo, and all other Oclaro, Inc product names and slogans are trademarks or registered trademarks of Oclaro, Inc. in the U.S.A. or other countries. Products described in this datasheet may be covered by one or more patents in the U.S.A. and abroad. Information in this datasheet is subject to change without notice.